

# ***Tournament Scale***

*by Agri-Tronix Corporation*



***Operators Manual***

***[www.tournamentcales.com](http://www.tournamentcales.com)***

# Chapter 1 Overview

---

The Tournament Scale Digital Indicator is an industrial grade weight indicator designed specifically for competition weighing applications.

**The indicator can readout up to 50,000 display divisions and is a Class III weighing instrument that can be certified by your local weights and measurements bureau.** The box is equipped with special screws that can be wire tied sealed after being certified. All setup parameters may be entered via the front panel keys, including calibration.

An internal 6V rechargeable battery is available as the primary power source. The external AC power supply with these units functions as a charger for the rechargeable battery. The AC power supply may also be used as the main power supply.

If your Tournament Scale Digital Indicator is part of a complete system that includes the pro-tournament weigh table or S-hook, you may skip to Chapter 7 for operating instructions. Prior to using the indicator, please read this chapter carefully and completely. Store the manual in a safe and convenient place so it will be available if you have questions concerning the operation of the scale.

If you are an installer, the indicator's installation and wiring instructions are found in Chapter 2. The indicator contains two main setup menus: The Setup ("F") menu, which configures the indicator to your weigh platform and the User ("A") menu, which configures the serial communication port and enables some user options. Chapter 3 gives an overview and explains how to use the five front panel keys to maneuver and save settings in both menus. Chapters 4 and 5 explain the Setup and User Menu options, respectively. Chapter 6 covers system calibration. Prior to installing the indicator, please read this manual carefully and completely. Store the manual in a safe and convenient place so it will be available if you have questions concerning the setup and operation of the scale.

## NOTE

---

This equipment has been tested and found to comply with the limits for a Class A digital device, pursuant to Part 15 of the FCC Rules. These limits are designed to provide reasonable protection against harmful interference when the equipment is operated in a commercial environment. This equipment generates, uses and can radiate radio frequency energy and, if not installed and used in accordance with the instructions manual, may cause harmful interference to radio communications. Operation of this equipment in a residential area is likely to cause harmful interference in which case the user will be required to correct the interference at his/her own expense.

# Chapter 2 Installation

## 2.1 Connector arrangement

The bottom of the indicator contains the power connector and two weather tight pass throughs to connect the weigh table and remote display or printer.

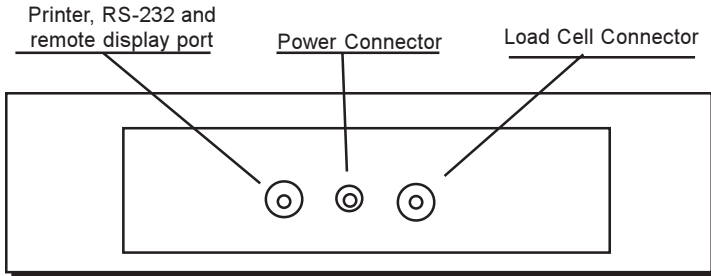
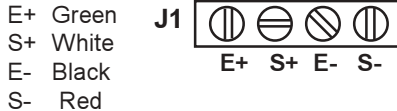

Fig. 2-1: Connector Location

### 2.1.1 CONNECTING THE LOAD CELL

The weigh table or load cell will have a 5-wire cable that connects to a terminal strip located inside the indicator. Using the picture below connect the cable to the J1 terminal strip.

E+ = Power Positive  
E- = Power Gnd  
S+ = Signal Positive  
S- = Signal negative



### 2.1.2 RECHARGEABLE BATTERY

The indicator's rechargeable battery ships pre-installed. The external AC charger (included) can also be used to power the indicator. It is recommended to charge the battery overnight for a full charge before a tournament event

### 2.1.3 CONNECTING THE SERIAL PRINTER, REMOTE DISPLAY OR COMPUTER

The Tournament Scale comes with an RS-232 port, designed for connection to either a PC or a serial printer. The same port may be also used as a simplex, RS-232 port designed for connection to a remote display. Connect the RS-232 cable to terminal strip J3 using the TXD and GND pins.

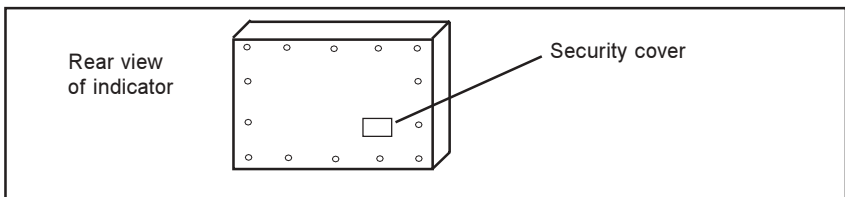

Fig. 2-2: security cover for setup switch

# Chapter 3 Configuration

## 3.1 Configuration Overview

The indicator contains two main setup menus:

The Setup (“F”) menu, which configures the indicator to your weigh platform and the User (“A”) menu, which configures the serial communication port and enables some user options. The Setup and User menus consist of several menu selections, each with its own sub-menu of choices. There is a flow chart of the options on Fig 3-2 (Page 6) and Fig 3-4 (Page 8).

To configure or make changes to the operation of the indicator, you must first enter the appropriate menu mode. Once there, four of the front panel keys become directional navigators to move around in the menus, the ”SET” key is used to save selections to nonvolatile memory.

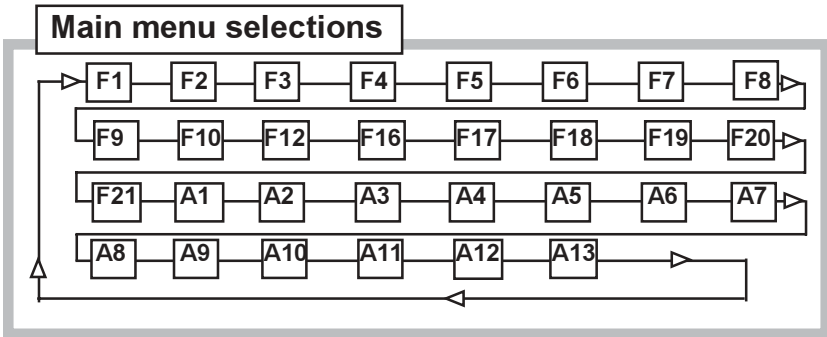

## 3.2 SETUP (“F”) Menu

### 3.2.1 ENTERING THE SETUP MENU

1. Power off the indicator (Hold the “ZERO/OFF “ key down until display blanks)
2. On the rear panel remove the small cover held in place by two security screws and move the switch to the opposite position (See Previous page Fig 2-2)
3. Power on the indicator by pressing the green “ON/PRINT” key. The indicator will display “F !” that indicates you are in the SETUP Menu Mode.

NOTE: Access to the Setup Calibration Switch is inhibited if the indicator has been sealed for legal for trade applications. For more information see chapter 8.

### 3.3.2 NAVIGATING THE SETUP MENU

Use the directional keys shown in Figure 3-1 to move around in the setup menu chart shown in Figure 3-2 on page 6.

# Chapter 3 Key Assignments

## 3.3 Setup Key Assignments

This section provides instructions for all of the User Menu procedures.

### 3.3.1 KEY ASSIGNMENTS

1. While in the User Setup mode the five keys on the front panel will be used to navigate the menus and enter data. (To enter setup mode: Turn off indicator, slide the switch under the small cover on rear of unit to "setup mode position" and power indicator back on.)
2. While in setup mode the five keys will have the following functions:

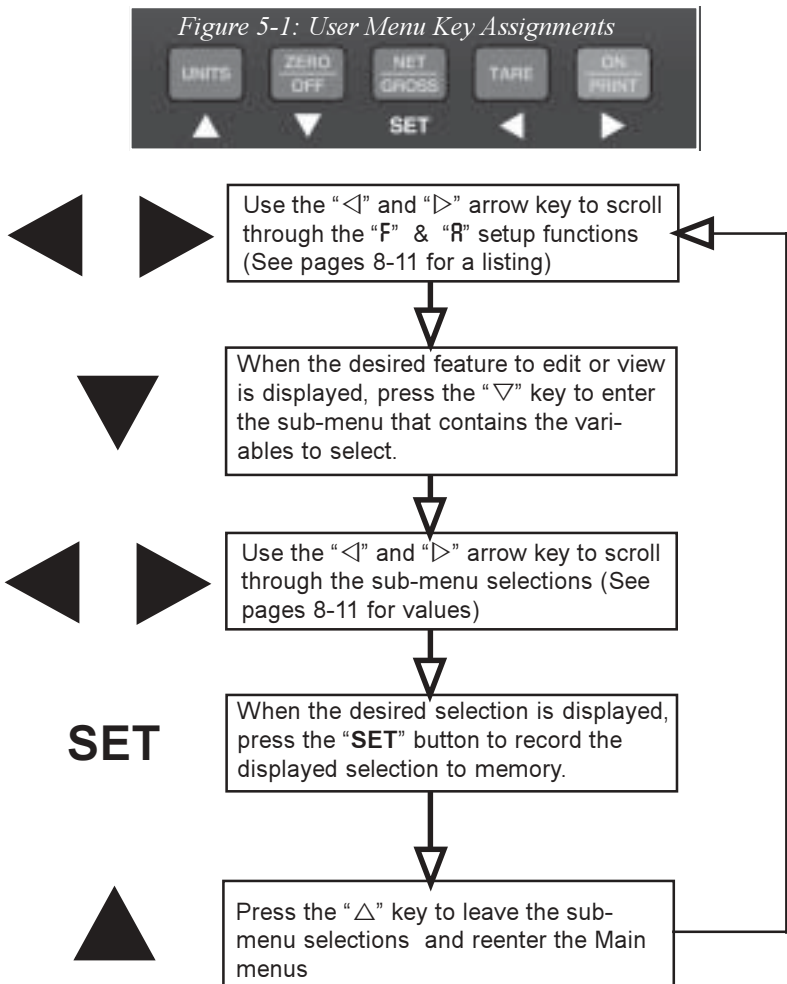

Fig 3-1

# Chapter 3 Key Assignment

## 3.3.1 (CONTINUED)

1. To move to a new “F” heading, use the ( ◀ ) key or ( ▶ ) key to move right or left in the Setup Menu Chart.
2. To move to the selection level, press the ( ▽ ) key once. The current saved selection in memory is displayed.
3. To view the available selections for the current “F” heading, use the ( ◀ ) key or ( ▶ ) key to move through the selection field.
4. To save a new selection, press the (SET) key.  
To exit without saving, press the ( △ ) key to return to the current “F” heading.
5. Repeat Steps 1 through 4 until the Setup Menu is programmed.

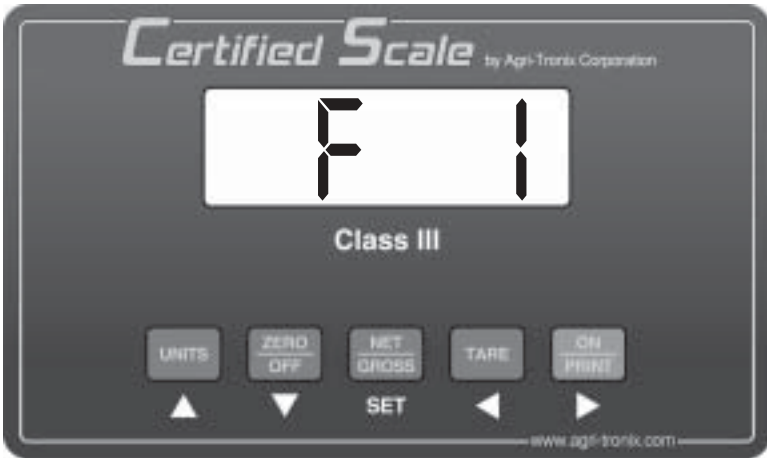
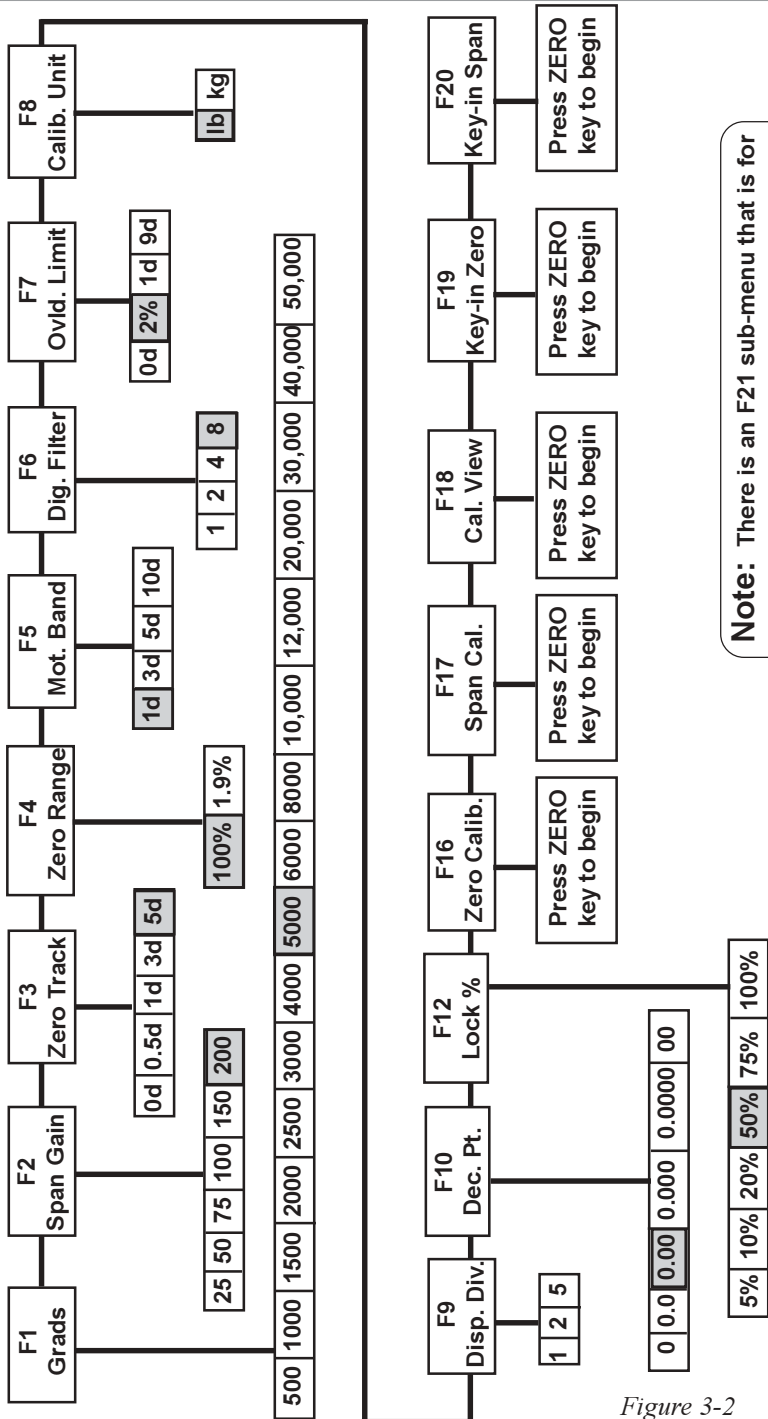

Figure 3-1

## 3.3.2 NOTES ON THE SETUP MENU

1. There is an F 21 sub-menu present that is for **FACTORY USE ONLY!**
2. Detailed descriptions of the setup menu parameters can be found in Chapter 4 of this manual.
3. The User “F” menu sub-menus appear when scrolling left or right from the “F” menu.

# Chapter 3 Setup Flow Chart



**Note:** There is an F21 sub-menu that is for FACTORY USE ONLY!

Figure 3-2

# Chapter 3 Configuration

## 3.2.5 EXITING THE SETUP MENU

1. Power off the indicator. (Press the ZERO/OFF key until display blanks)
2. Move the slide switch on the rear cover back to the original position.
3. Power on the indicator. The display will go through self test computer check, and then enter Normal Operating mode. All front panel keys will now return to their normal mode of operation.

## 3.3 User (“A”) Menu

### 3.3.1 ENTERING THE USER MENU

1. Enter the Setup “F” menu by following the directions in Section 3.2.1 or 3.2.2.

#### Procedure to enable SETUP MODE

1. Power off unit. (Press “ZERO/OFF” until display blanks)
2. Move slide switch under small cover on rear of unit to the opposite position of “normal weigh mode”.
3. Power unit back on.

2. Use the right  $\triangleright$  or left  $\triangleleft$  directional keys to advance through the selections in the Setup “ F ” menu until the indicator displays “ F ! ”.

### 3.3.2 NAVIGATING IN THE USER MENU

Use the directional keys shown in Figure 3-1 to move around in the User Menu Chart shown in Figure 3-4 on the following page.

1. To move to a new “ F ” heading, use the TARE ( $\triangleleft$ ) or PRINT ( $\triangleright$ ) key to move right or left in the User Menu Chart.
2. To move to the selection level, press the ZERO ( $\nabla$ ) key once. The current saved selection is shown.
3. To view the available selections for the current “ F ” heading, use the TARE ( $\triangleleft$ ) or PRINT ( $\triangleright$ ) key to move through the selection field.
4. To save a new selection, press the NET/GROSS (SET) key . To exit without saving, press the UNITS ( $\triangle$ ) key to return to the current “A” Menu item.
5. Repeat Steps 2 through 4 until the User Menu is programmed.

# Chapter 3 Configuration

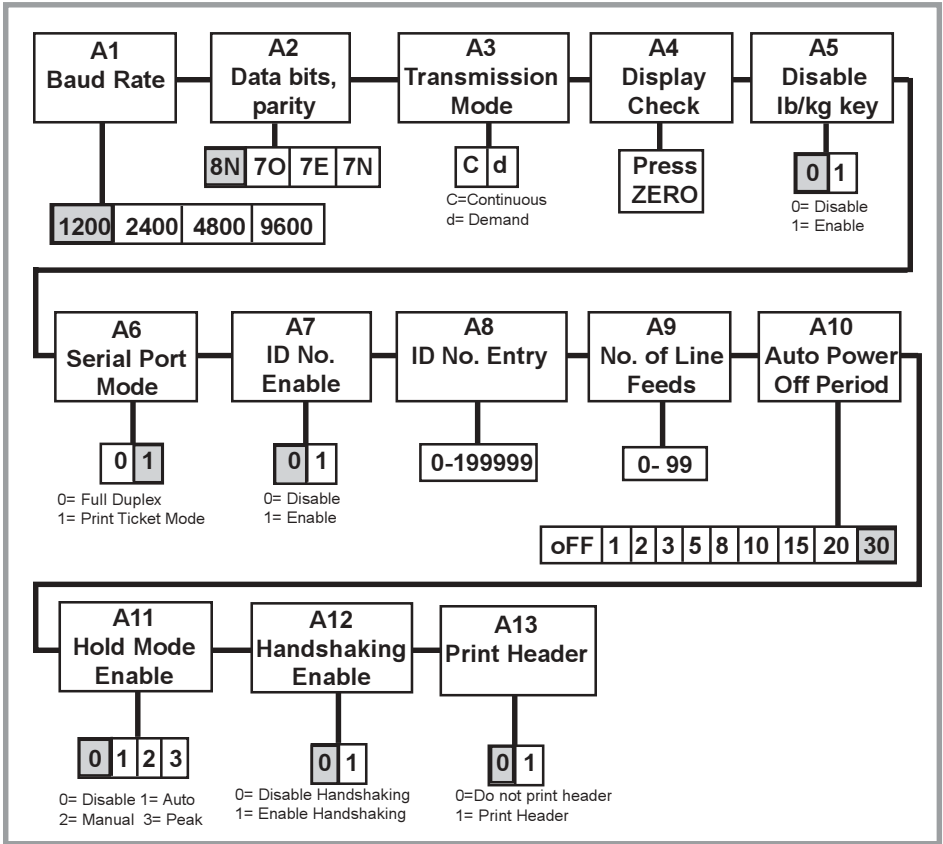

Figure 3-4

## 3.3.3 NOTES ON THE USER MENU

1. Detailed descriptions of the user menu parameters can be found in Chapter 5 of this manual.

## 3.3.4 EXITING THE USER MENU

1. Exit the User “ $\square$ ” menu by following the directions in Section 3.2.5 The display will go through a digit check, then enter into Normal Operating mode. All front panel keys will now return to their normal mode of operation.

# Chapter 4 Setup Menus

## 4.1 Setup Menu Descriptions

This section provides more detailed descriptions of the selections found in the Setup Menu Chart. Factory-set defaults are shown in bold with a check mark (✓).

Table 4-1 shows selections that are not allowed for "Legal for Trade" applications.

### Setup function descriptions and values

Name/Code	Description	Code/Value
<b>F1</b> Graduations	Specifies number of full-scale graduations. Value should be consistent with legal requirements and environmental limits on the useful system resolution.	500 1,000 1,500 2,000 2,500 3,000 4,000 <b>5,000</b> ✓ 6,000 8,000 10,000 12,000 20,000 30,000 40,000 50,000
<b>F2</b> Span Gain	Span Gain is related to A/D integration time. The larger the span gain, the higher the internal resolution, but the slower the update speed. Note that the scale must be re-calibrated whenever this parameter is altered. See Appendix C for more information.	25 50 75 100 150 <b>200</b> ✓
<b>F3</b> Zero Track Band	Selects the range within which the scale will automatically zero. Note that the scale must be in standstill to automatically zero. Selections are in Display Divisions.	0d 0.5d 1d 3d <b>5d</b> ✓
<b>F4</b> Zero Range	Selects the range within which the scale may be zeroed. Note that the indicator must be in stand still to zero the scale.	<b>100%</b> ✓ 1.9%
<b>F5</b> Motion Band	Sets the level at which motion is detected by comparing the present display update with the previous one. If motion is not detected for two seconds or more, scale is in standstill and can process a Print or Zero command. Maximum value varies depending on local regulations.	<b>1d</b> ✓ 3d 5d 10d

# Chapter 4 Setup Menus

Name/Code	Description	Code/Value
<b>F6</b> Digital Filter	Averages weight readings to produce higher stability. The higher the filter setting, the greater the stability but the slower the indicator's response time.	1 2 4 <b>8✓</b>
<b>F7</b> Overload Limit	Selects the desired formula which determines the point at which the indicator shows overload. All selections are based on the primary unit selected in F8. "FS" = Full scale in primary units.	FS <b>FS + 2%✓</b> FS + 1d FS + 9d
<b>F8</b> Calibration Units	Selects the primary base unit to be used in the calibration process. Also the default unit for normal operation. <b>"1" = lb. "2" = kg.</b>	<b>1✓</b> 2
<b>F9</b> Display Divisions	Determines the desired weight increments. Value should be consistent with legal requirements.	<b>1✓</b> 2 5
<b>F10</b> Decimal Point	Determines location of the decimal point.	0      0.0 <b>0.00✓</b> 0.000 0.0000   00
<b>F12</b> Motion Lock %	Determines the amount of weight that must be added or removed to unlock displayed value	5%    10% 20% <b>50%✓</b> 75%    100%
<b>F16</b> Zero Calibration	Places indicator into the zero calibration routine. Scrolling down with the <b>ZERO</b> key one level begins the procedure.	Press <b>ZERO</b> key to begin sequence
<b>F17</b> Span Calibration	Places indicator into the span calibration routine. Scrolling down with the <b>ZERO</b> key one level begins the procedure.	Press <b>ZERO</b> key to begin sequence
<b>F18</b> View Calibration	Actuates the function that allows you to view both the zero and span calibration value.	Press <b>ZERO</b> key to begin sequence
<b>F19</b> Key-in Zero	Allows you to key-in known zero calibration value in case of memory loss in the field. Scrolling down with the <b>ZERO</b> key one level begins the procedure.	Press <b>ZERO</b> key to begin sequence
<b>F20</b> Key-in Span	Allows you to key-in a known span calibration value in case of memory loss in the field. Scrolling down with the <b>ZERO</b> key one level begins the procedure.	Press <b>ZERO</b> key to begin sequence
<b>F21</b> Factory Reset	Pressing this menu will reset all parameters in the "F" and "A" menu to the default settings. <b>USE WITH CAUTION!</b>	Press the <b>ZERO</b> key twice to execute.

# Chapter 5 User Menu

Sub-Menu	Title	Selections			
F1	Graduations	6,000 12,000 40,000	8,000 20,000 50,000	10,000 30,000	
F3	Zero tracking Band	0d 5d			
F5	Motion Band	3d 20d	5d 30d	10d 40d	15 d 50d
F6	Digital Filter	1	2	4	

Table 4-1: Invalid Setup Menu selections in Legal-for-Trade applications

## 5.1 User Menu Descriptions

This section provides more detailed descriptions of the selections found in the User Menu Chart. Factory-set defaults are shown in bold with a check mark (✓).

Name/Code	Description	Code/Value
<b>A1</b> Baud Rate	Selects the baud rate for data transmission through the serial port.	<b>1200</b> ✓ 2400 4800 9600 19200
<b>A2</b> Data Bits and Parity	Selects the number of data bits and parity of serial transmission. "8n" = 8 data bits, no parity, one stop bit "7O" = 7 data bits, odd parity, one stop bit "7E" = 7 data bits, even parity, and one stop bit "7n" = 7 data bits, no parity bit, two stop bits	<b>8n</b> 7O 7E 7n
<b>A3</b> Mode of Serial Transmission	Selects when data will be sent out of the serial port to a printer or computer: "C" = Continuous mode; send data continuously "d" = Demand mode; send data when a PRINT command is issued from the printer, computer, or indicator.	<b>C</b> ✓ d
<b>A4</b> Display Check	Actuates the function that illuminates all digit segments, decimal points, and LCD annunciators in a test sequence. Pressing the <b>ZERO</b> key to scroll down one level begins the test sequence.	Press <b>ZERO</b> key to begin sequence
<b>A5</b> Disable the lb/kg key	Allows the lb/kg key to be disabled so that an operator cannot accidentally press the key and change the displayed units. "0" = Disable the lb/kg key "1" = Enable the lb/kg key	<b>0</b> ✓ 1

# Chapter 5 User Menu

Name/Code	Description	Code/Value
<b>A6</b> Serial Port Mode	Selects the mode of the RS-232 serial port: Refer to Appendix B for more information. "0" = Full Duplex Mode "1" = Print Ticket Mode	<b>0✓</b> 1
<b>A7</b> ID No. Enable	Allows the ID number to be disabled in the Print Ticket mode. Valid only when <b>A6</b> is set to "1". "0" = Disable the ID No. "1" = Enable the ID No.	<b>0✓</b> 1
<b>A8</b> ID No. Entry	Actuates the function that allows entry of a new ID No. Valid only when <b>A6</b> is set to "1". Pressing the <b>ZERO</b> key to scroll down one level begins the sequence.	0 - 999999 <b>123456✓</b>
<b>A9</b> No. of line feeds	Actuates the function that allows entry of the desired number of line feeds to be printed in Print Ticket Mode. Valid only when <b>A6</b> is set to "1". Pressing the <b>ZERO</b> key to scroll down one level begins the sequence	0 – 99 <b>8✓</b>
<b>A10</b> Auto Power Off	Selects the auto off time period in minutes: "Off" = Disabled (Always ON)	<b>Off✓</b> 3            5 10          20 30
<b>A11</b> Hold Enable	Activates the "Hold" mode where weight of the object on the platform is frozen on the display until the applied weight is decreased by a percentage of displayed weight. "0" = Disabled, "1" = Auto "2" = Manual, "3" = Peak	0 <b>1✓</b> 2 3
<b>A12</b> Handshaking Enable	Enables hardware handshaking for Print Ticket Mode. Valid only when <b>A6</b> is set to "1". "0" = Disabled      "1" = Enabled	<b>0✓</b> 1
<b>A13</b> Print Header	Informs select printers to print the header information. Valid only when <b>A6</b> is set to "1". "0" = Do not print header "1" = Print Header	<b>0✓</b> 1

# Chapter 6 Calibration

## Chapter 6: Calibration

### 6.1 CALIBRATION OVERVIEW

The indicator is calibrated by following the procedures embedded in **F 16** (Zero) and **F 17** (Span) of the Setup Menu. Each procedure enters a value into the indicator's nonvolatile memory - **F 16** is the zero value (deadweight) and **F 17** is the span value (test weight). The minimum test weight that can be used is 1% of full-scale capacity. After the two calibration procedures are executed successfully, you should record both calibration values in Table 6-1 using the **F 18** View procedure.

In the unlikely event that either value is lost while in the field, the setup menu makes provisions for reentering these values via **F 19** and **F 20**, thus eliminating the need for re-calibration with test weights.

**NOTE:** This chapter assumes that the indicator is in Setup "F" Menu mode. If the indicator is not in Setup Menu mode, refer to Chapter 3 for instructions.

### 6.2 ZERO CALIBRATION (F 16)

1. While in the Setup mode, scroll to "**F 16**", then scroll down once using the "**▽**" key to enter zero calibration menu. The display will momentarily show "**┌ 0**" followed by a value. This value is the internal A/D count and can prove useful when trying to troubleshoot setup problems.
2. After making sure that there are no test weights on the platform, press the "**▽**" key again to zero out the displayed value.
3. Press the "**SET**" key to save the zero point value. The display will show "**END0**" momentarily, then revert back up to "**F 16**". At this time, proceed to the **F17** span calibration to complete indicator calibration.

### 6.3 SPAN CALIBRATION (F 17)

1. While in the Setup mode, scroll to "**F 17**", then scroll down once using the "**▽**" key to enter the span calibration menu.
2. The display will momentarily show "**┌ 1**" for the span calibration, followed by a value with one flashing digit. This value will be zero with the Decimal Point parameter selected in "**F 10**". Place the test weight on the load cell.
3. Use the four directional keys (shown in Figure 6-1 below) to adjust the displayed value to the actual test weight value. Increase the flashing digit by pressing the "**△**" key. Decrease the flashing digit by pressing the "**1**" key. Pressing the "**▷**" key or the "**◁**" key will change the position of the flashing digit.

# Chapter 6 Calibration

4. After setting the exact value, press the “**SET**” key to save the value.
5. If the calibration was successful, the display will show “**END!**” momentarily, then revert back up to **F 17**. At this time it is suggested that the calibration values be recorded for future use (see Section 6.4).
6. If the calibration was *not* successful, one of the error messages below will appear. Take the indicated action to correct the problem, then perform a new calibration.

“**Err0**” - The calibration test weight or the adjusted keyed-in weight is larger than the full capacity of the scale. Change the calibration test weight or check the input data.

“**Err1**” - The calibration test weight or the adjusted keyed-in weight is smaller than 1% of the full capacity of the scale. Change the calibration test weight or check the input data.

“**Err2**” - The internal resolution of the scale is not high enough to accept the calibration value. Select a larger parameter for the Span Gain “**F 2**”.  
SEE APPENDIX C FOR MORE INFORMATION.

## 6.4 VIEW CALIBRATION VALUES (F 18)

**Note:** The values displayed in this procedure are valid only after a successful calibration has been performed using F16 and F17.

1. While in the Setup mode, scroll to “**F 18**”, then scroll down once using the “**▽**” key to enter “View calibration” menu.
2. The display will momentarily show “**CR 0**” followed by a value. This value is the **zero calibration value** and should be recorded in the table below. Press any key to continue.
3. The display will momentarily show “**CAL 1**” followed by another value. This value is the **span calibration value** and should also be recorded in the table below. Press any key to return to upper level (F18).

Zero Calibration Value	Span Calibration Value

*Table 6-1: Calibration Value Table*

# Chapter 6 Calibration

---

## 6.5 KEY-IN ZERO CALIBRATION VALUE (F 19)

---

**Note:** This procedure is intended for emergency use only in the case of nonvolatile memory loss. A valid zero calibration value, obtained from a successful F 15 calibration procedure, must be used.

1. While in the Setup mode, scroll to “F 19”, then scroll down once using the ZERO key.
2. The display will momentarily show “CAL 0”, followed by a flashing zero. Use the four directional keys (shown in Figure 6-1) to adjust the displayed value to the zero calibration value.
3. After setting the exact value, press the “SET” key to save the value.
4. The display will show “E CAL 0” momentarily, then revert back up to F 19.

## 6.6 KEY-IN SPAN CALIBRATION VALUE (F 20)

---

**Note:** This procedure is intended for emergency use only in the case of nonvolatile memory loss. A valid span calibration value, obtained from a successful F 17 calibration procedure, must be used.

1. While in the Setup mode, scroll to “F 20”, then scroll down once using the “▽” key.
2. The display will momentarily show “CAL 1”, followed by a flashing zero. Use the four directional keys (shown in Figure 6-1) to adjust the displayed value to the span calibration value.
3. After setting the exact value, press the ”SET” key to save the value.
4. If the entered value is greater than zero, the display will show “E CAL 1” momentarily, then revert back up to “F 20”. If a value of zero is entered, the indicator will briefly show “ERR 5”, then revert back to the screen described above in Step # 2.

# Chapter 7 Operation

## CHAPTER 7: OPERATION

### 7.1 DISPLAY

The Tournament Scale utilizes a 6 digit LCD (Liquid Crystal Display). Typically, LCD's are used for outdoor applications where the display must be readable in bright sunlight. The display also incorporates a backlight so the display can be read in low light conditions.

#### 7.1.1 LIQUID CRYSTAL DISPLAY (LCD)



Icons	Meaning
→ 0 ←	Better known as the "Center of Zero" annunciator, this light is active whenever the displayed weight is within $\pm 0.25$ divisions of true zero.
N	Indicates that the indicator is displaying net weight.
G	Indicates that the indicator is displaying gross weight.
T	Indicates that a tare weight has been established in the system.
P	Indicates Unit is in peak hold mode (A11 must be set to 3)
lb,kg	Indicates the unit of the displayed weight.
	This icon is on whenever the scale is stable.
	Motion Lock indicator. These two arrows will appear under the numbers when the scale is in "motion lock"

Table 7-1: Icon definitions

### 7.2 KEYBOARD

The keyboard is composed of five function keys. Refer to Figures 7-3 for the overall layout and key locations.



Table 7-3: Icon definitions

# Chapter 7 Operation

---

## 7.2.1 FUNCTION KEYS

**UNITS** – This key toggles the indicator among the available weight units if enabled in the User (“F”) menu. Available weight units include lb, kg and pieces. See Chapter 5 for more information. (The ability to change units can be disabled in the setup routine)

**ZERO** - This key sets the indicator to display zero provided the following conditions are met:

1. The indicator is displaying Gross weight.
2. The displayed weight is within the zero reset range that is programmed in F4 of the Setup (“F”) Menu.
3. The scale is not in motion.
4. The scale is not in overload (see Appendix D for error codes).

**ZERO/OFF** – Same as ZERO key except when held for five seconds, shuts the unit off.

**NET/GROSS** - This key toggles the indicator between Gross weight and Net weight only if a Tare has been established.

**TARE** - This key is used to establish a Tare provided the following conditions are met:

1. The indicator is not at or below Gross zero.
2. The scale is not in motion.
3. The scale is not in overload (see Appendix D for error codes).

**PRINT** - This key is used to send weight information out to the serial port provided the following conditions are met:

1. The scale is not in motion.
2. The scale is not in overload (see Appendix D for error codes).

**ON/PRINT** – Same as PRINT key except when the unit is off, turns the unit on.

**UNITS** -Toggles between Pounds and Kilograms if A5 is set to “1”  
Turns Peak hold mode off and on if A11 is set to “3”

# Chapter 7 Operation

---

## 7.3 GENERAL SCALE OPERATION

---

### 7.3.1 WEIGHING AN ITEM

1. Select the desired weighing unit by pressing the lb/kg key until that unit is indicated on the display.
2. If necessary, press the “ZERO” key to obtain a weight reading of zero.
3. Place the object to be weighed on the scale’s load cell and allow the weight indication to stabilize. If the item weight exceeds the scale’s weight capacity, it displays “**00000**”.
4. Read the weight shown on the display.

### 7.3.2 TARING AN ITEM

To weigh an item in a container, the weight of that container must first be subtracted from the overall weight to obtain an accurate weight reading. This is known as taring.

1. Select the desired weighing unit by pressing the lb/kg key until that unit is indicated on the display.
2. If necessary, press the ZERO key to obtain a weight reading of zero.
3. Place the empty container on the scale’s load cell and allow the weight indication to stabilize.
4. Press the TARE key. The display shows zero weight and turns the NET annunciator on.
5. Place the material to be weighed in the container and allow the indication to stabilize.
6. Read the weight shown on the display.
7. You may toggle between the gross weight and the net weight by pressing the NET/GROSS key.

## CHAPTER 8: LEGAL FOR TRADE SEALING

---

1. Power off the indicator.
2. On the rear cover of the indicator, locate the calibration switch cover.
3. Thread a wire security seal through both drilled head screws securing the calibration switch cover as well as the two drilled head screws holding on the rear panel.

# Appendix A

---

## **Analog Specifications**

Full Scale Input Signal	30mV, including dead load
Minimum Sensitivity - Non H-44	0.4 $\mu$ V / grad
Minimum Sensitivity - H-44	1.0 $\mu$ V / grad
Input Impedance	30M $\Omega$ , typical
Internal Resolution	Approximately 260,000 counts
Display Resolution	50,000 display division max
Measurement Rate	10 Meas/sec, nominal
System Linearity	Within 0.02% of FS
Calibration Method	Software Calibration, with storage in EEPROM
Excitation Voltage –	+5 VDC 4 x 350 $\Omega$ load cells

---

## **Digital Specifications**

Microcontroller –	S200-SL Winbond W78E58
Program Memory -	64K x 8, external to $\mu$ C
EEPROM:	64 x 16, external to $\mu$ C
Digital Filtering	Software selectable

---

## **Serial Communications**

Serial Port Full Duplex, 1200, 2400, 4800, 9600 Baud  
8 data bits, no parity, 1 stop bit  
7 data bits, odd parity, 1 stop bit  
7 data bits, even parity, 1 stop bit  
7 data bits, no parity, 2 stop bits

---

## **Operator Interface**

Display – LCD Indicators 0.8" (20 mm) 7-segment, Liquid Crystal, 6 Digit  
Additional Symbols - Net, Gross, Stable, Tare, lb, kg, Zero,

---

## **Power**

Rechargeable Battery	6 VDC, 3.0 Ah sealed lead acid
AC Adapter –	12 VDC, 800mA
DC Power Consumption -	80mA + 15mA/350 $\Omega$ Load Cell

---

## **Environmental**

Operating Temperature –10° to +40° C  
Storage Temperature -25° to +70° C

---

## **Mechanical**

Overall Dimensions (L x W x H) –	10.4" x 3.1" x 7.7"
----------------------------------	---------------------

---

# Appendix B

## B.1 SERIAL PORT MODES

### B.1.1 FULL DUPLEX MODE

The **Full Duplex Mode** provides a Demand serial transmission mode and is selected by setting  $\text{R } 3$  to “d” and  $\text{R } 6$  to “0”. The Demand mode allows control from a host device, usually a PC, and can be activated by pressing the PRINT key on the indicator’s front panel. Figure B-1 shows a suggested cable diagram for interface to a PC. Figure B-2 shows the serial data format for the Demand Mode.

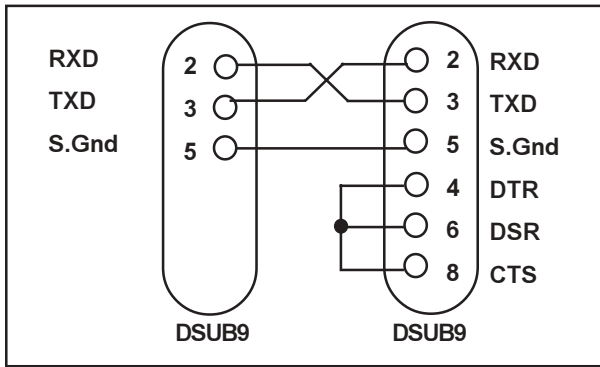

Figure B-1: Cable Diagram for indicator to Computer

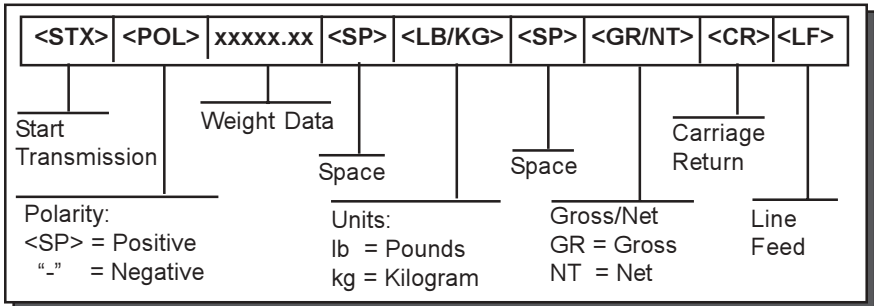

Figure B-2 RS-232 Serial String output

# Appendix B

---

## B.1.1.1 RECOGNIZED HOST COMMANDS

- “**P**” - This command is sent to the indicator to print the indicated display. The indicator will not respond if the scale is in motion, positive overload or negative overload.
- “**Z**” - This command is sent to the indicator to zero the scale. The indicator will not respond if the scale is in motion, positive overload or negative overload. The indicator will also not respond if it is not in gross mode or within the zero range specified in F4 of the Setup Menu.
- “**T**” - This command is sent to the indicator to tare the scale. The indicator will not respond if the scale is in motion, positive overload or negative overload. The indicator will also not respond if it displaying a negative gross value.
- “**G**” - This command is sent to the indicator to revert to gross mode. The indicator will not respond if the scale is in motion, positive overload or negative overload. The indicator will also not respond if it is not in net mode.
- “**N**” - This command is sent to the indicator to revert to net. The indicator will not respond if the scale is in motion, positive overload or negative overload. The indicator will also not respond if it is not in gross mode or a tare has yet to be established.
- “**C**” - This command is sent to the indicator to toggle among the configured units (pounds or kilograms).

## B.1.2 PRINT TICKET MODE

The Print Ticket Mode is designed specifically for a serial printer and is selected by setting  $\text{F} 5$  to “1”. Figure B-3 shows the fixed format of the print ticket.

For printers with limited buffers, this mode supports DTR pin handshaking. The DTR pin from the serial printer is wired to the indicator’s RXD pin which then functions as a CTS pin.

Figure B-4 shows a suggested cable diagram for interfacing to a serial printer. Refer to the printer’s user manual to confirm which pin is the DTR pin.

### NOTES:

1. The TARE and NET fields are not printed unless a tare has been established in the system.
2. The ID number field is not printed if it is disabled in  $\text{F} 7$  of the User Menu.

ID . NO .	1	2	3	4	5	6
GROSS	2	5	.	0	0	LB
TARE	1	.	4	8		LB
NET	2	3	.	5	2	LB

*Figure B-3 Print Ticket*

# Appendix B

## B.1.3 PRINTER CABLE

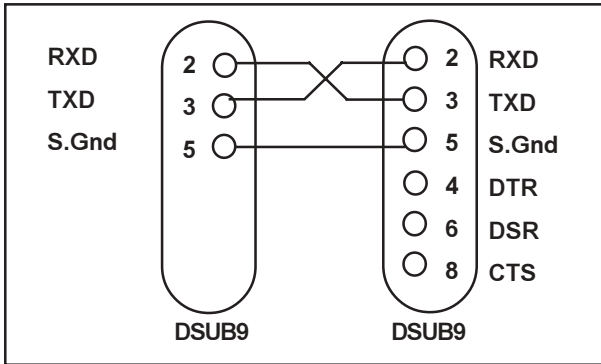

Figure B-1: Cable Diagram for indicator to Printer

## B.1.4 SIMPLEX MODE

The Simplex Mode provides a continuous serial transmission mode and is selected by setting **R 3** to “**L**” and **R6** to “**0**”. The Continuous mode is used to interface to computers, score boards, and other remote devices requiring constant data updating. The transmission occurs at the end of each display update. Figure B-5 shows the serial **data format for Continuous Mode**.

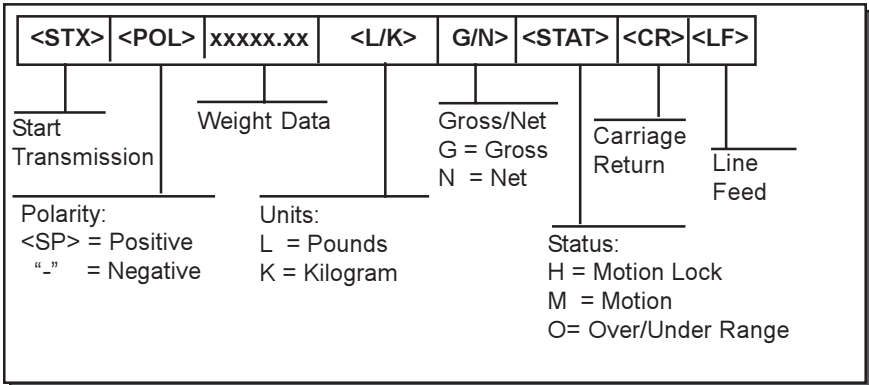

Figure B-2 RS-232 Serial String output continuous mode

# Appendix C

---

## APPENDIX C: DETERMINING PROPER SPAN GAIN (F 2)

### C.1 SPAN GAIN OVERVIEW

---

The Span Gain parameter found in F 2 of the Setup Menu is directly related to the ADC (Analog to Digital Converter) integration time. This means that the lower the setting, the higher the number of measurements per second. A span gain setting of **25** produces about 25 to 30 measurements per second, while a span gain of **200** produces only about 3 or 4 measurements per second.

There is really no wrong setting for span gain – except in two cases. Using a low setting for a high resolution, low output system could yield instability. Using a high setting in a high output system could yield non-linearity.

### C.2 SETTING THE INITIAL VALUE FOR SPAN GAIN

---

1. Determine the number of desired external graduations and choose the corresponding value listed in Table C-1 or Table C-1a under the number closest to your full-scale input range in millivolts.
2. Enter the Setup Menu and save this number for the Span Gain parameter in F 2.
3. Perform a system calibration. If the calibration proves unsuccessful, or you wish to view the internal counts, proceed to the next set of instructions.

### C.3 VIEWING THE INTERNAL COUNTS(F 15)

---

1. Enter the zero calibration menu (F 15) and follow steps 1 to 3, *but do not save the zero point*.
2. After pressing the **ZERO** key to zero the offset, place the test weight(s) on the platform. The displayed count is the internal count. If the count remains on zero, check your load cell connections.
3. At full scale, the displayed count should be a minimum of 2 times the desired external graduations. However, for maximum stability, a ratio of 6:1 or higher is recommended.
4. If the displayed count is large enough, remove the test weight(s), re-zero the indicator if necessary, and proceed with the calibration. If the displayed number is *not* large enough, increase the Span Gain to the next highest choice in the Setup Menu and re-calibrate.

# Appendix D Error Codes

## APPENDIX D: DISPLAYED ERROR CODES

CODE	MODE	MEANING/POSSIBLE SOLUTION
<b>00000</b>	<b>Normal Operating Mode</b>	Gross Overload. A weight greater than the rated capacity has been applied to the scale or the load cell is not connected to the indicator. Remove the weight from the platter if overloaded or try recalibrating the scale if this is a new installation.
<b>ERR 0</b>	<b>Span Calibration Mode(F17)</b>	Keyed-in weight value is larger than full-scale capacity. Use a smaller test weight or check keyed-in value.
<b>ERR 1</b>	<b>Span Calibration Mode(F17)</b>	Keyed-in weight value is less than 1% of full-scale capacity. Use a larger test weight or check keyed-in value.
<b>ERR 2</b>	<b>Span Calibration Mode(F17)</b>	There is not enough load cell signal to produce the internal counts necessary to properly calibrate the scale. First check all load connections. Use F16 mode to view internal counts.
<b>ERR 3</b>	<b>All Modes</b>	Nonvolatile memory read error. One or more setup parameters have been lost.
<b>ERR 4</b>	<b>All Modes</b>	Nonvolatile memory write error. Indicator needs service.
<b>ERR 5</b>	<b>Key-in Span Calibration Mode(F20)</b>	You have attempted to enter a zero value for C1. Enter a known calibration value greater than zero.
<b>ERR 7</b>	<b>Initialization</b>	No reading from the ADC. Make sure there is a load cell(s) connected to the indicator at start-up.
<b>ERR9</b>	<b>Normal Operating Mode</b>	Span calibration value has been lost. Recalibrate the scale.
	<b>Normal Operating Mode</b>	Indicates that the battery voltage is too low for normal operation. For alkaline battery units, replace the batteries. For rechargeable battery units, recharge the battery.
<b>Flashes "bAtt"</b>	<b>Normal Operating Mode</b>	Indicates that the battery voltage is too low for normal operation. For rechargeable battery units, recharge the battery.

Built to last  
a lifetime.....